

# Class 400 - Standard Connection Specifications

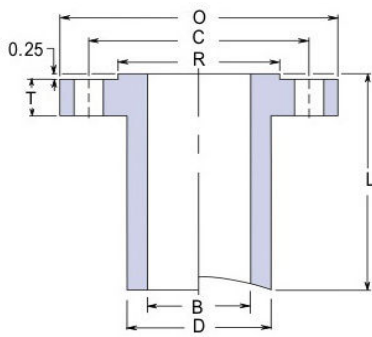

LONG WELD NECK "LWN"

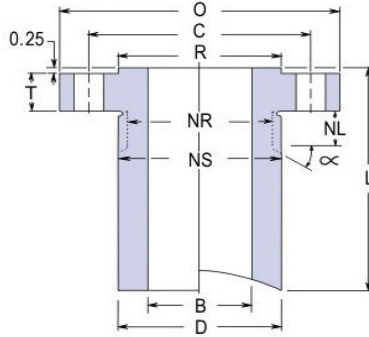

HEAVY BARREL "HB"

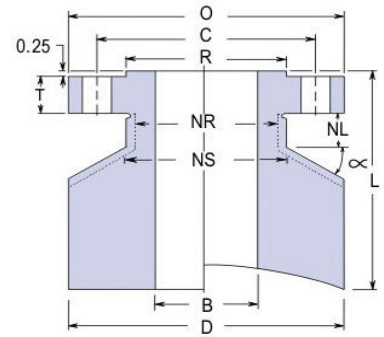

EQUAL BARREL "E"

Size		Flange			Barrel OD			Bolting			Nut			Stud Bolt			Weights					Length		
Nom	Bore LWN & E	Bore HB	OD	Thk.	RF of OD	LWN	HB	E	# of Holes	Hole Size	Bolt Circle	Stop Dia	Relief Dia	Relief Length	Size	RF Length	RTJ Length	LWN		HB		E		Base
	B	B	O	T	R	D	D	D			C	NS	NR	NL				Base	Per 1"	Base	Per 1"	Base	Per 1"	L
1/2	0.50	0.55	3.75	0.56	1.38	1.50	1.75	3.75	4	0.62	2.62	1.75	1.50	0.75	1/2	3	3	5	0.4	7	0.6	24	3.1	9
3/4	0.75	0.74	4.62	0.62	1.69	1.88	2.19	4.62	4	0.75	3.25	2.19	1.88	0.88	5/8	3 1/2	3 1/2	8	0.7	11	0.9	37	4.6	9
1	1.00	0.96	4.88	0.69	2.00	2.12	2.44	4.88	4	0.75	3.50	2.44	2.12	0.88	5/8	3 1/2	3 1/2	9	0.8	12	1.1	40	5.1	9
1 1/4	1.25	1.28	5.25	0.81	2.50	2.50	2.81	5.25	4	0.75	3.88	2.81	2.50	0.88	5/8	3 3/4	3 3/4	13	1	15	1.4	45	5.8	9
1 1/2	1.50	1.50	6.12	0.88	2.88	2.75	3.25	6.12	4	0.88	4.50	3.25	2.75	1.00	3/4	4 1/4	4 1/4	16	1.2	21	1.9	61	7.8	9
2	2.00	1.94	6.50	1.00	3.62	3.31	3.94	6.50	8	0.75	5.00	3.94	3.31	0.88	5/8	4 1/4	4 1/4	20	1.5	29	2.6	68	8.5	9
2 1/2	2.50	2.32	7.50	1.12	4.12	3.94	4.63	7.50	8	0.88	5.88	4.63	3.94	1.00	3/4	4 3/4	4 3/4	27	2.1	39	3.6	88	11	9
3	3.00	2.90	8.25	1.25	5.00	4.62	5.38	8.25	8	0.88	6.62	5.38	4.62	1.00	3/4	5	5	36	2.7	50	4.6	104	13	9
3 1/2	3.50	3.36	9.00	1.38	5.50	5.25	5.81	9.00	8	1.00	7.25	5.81	5.25	1.12	7/8	5 1/2	5 1/2	45	3.4	61	5.5	116	15	9
4	4.00	3.83	10.00	1.38	6.19	5.75	6.44	10.00	8	1.00	7.88	6.44	5.75	1.12	7/8	5 1/2	5 1/2	65	3.8	93	6.5	197	19	12
5	5.00	4.81	11.00	1.50	7.31	7.00	7.81	11.00	8	1.00	9.25	7.81	7.00	1.12	7/8	5 3/4	5 3/4	88	5.3	127	9.1	229	22	12
6	6.00	5.76	12.50	1.62	8.50	8.12	9.19	12.50	12	1.00	10.62	9.19	8.12	1.12	7/8	6	6	110	6.7	169	12	286	27	12
8	8.00	7.62	15.00	1.88	10.62	10.25	11.38	15.00	12	1.12	13.00	11.38	10.25	1.25	1	6 3/4	6 3/4	154	9.1	233	17	379	36	12
10	10.00	9.56	17.50	2.12	12.75	12.62	13.44	17.50	16	1.25	15.25	13.44	12.62	1.38	1 1/8	7 1/2	7 1/2	218	13	298	21	475	46	12
12	12.00	11.38	20.50	2.25	15.00	14.75	15.75	20.50	16	1.38	17.75	15.75	14.75	1.50	1 1/4	8	8	285	16	401	28	627	62	12
14	14.00	14.00	23.00	2.38	16.25	16.75	18.25	23.00	20	1.38	20.25	18.25	16.75	1.50	1 1/4	8 1/4	8 1/4	336	19	467	32	758	74	12
16	16.00	16.00	25.50	2.50	18.50	19.00	20.31	25.50	20	1.50	22.50	20.31	19.00	1.62	1 3/8	8 3/4	8 3/4	418	23	542	37	884	88	12
18	18.00	18.00	28.00	2.62	21.00	21.00	22.56	28.00	24	1.50	24.75	22.56	21.00	1.62	1 3/8	9	9	482	26	645	43	1033	102	12
20	20.00	20.00	30.50	2.75	23.00	23.12	24.63	30.50	24	1.62	27.00	24.63	23.12	1.75	1 1/2	9 1/2	9 3/4	568	30	759	50	1165	118	12
24	24.00	24.00	36.00	3.00	27.25	27.62	29.25	36.00	24	1.88	32.00	29.25	27.62	2.00	1 3/4	10 1/2	11	804	42	1040	67	1540	160	12

*Dimensions are in inches. Weights are in pounds.*